



# **INSPIREEE**



**INSPIRATIONAL SCRIPTS,  
PERSONALITIES AND INNOVATIVE  
RESEARCH OF EEE  
NEWS LETTER EEE/**

**VOLUME 7: ISSUE 3 JANUARY 2019**



**K.L.N. COLLEGE OF ENGINEERING**

(Accredited by NAAC for 5 Years W.e.f November 2018)

**Pottapalayam -630612,  
Sivagangai District,  
Tamilnadu**

# INSPIREEE

**IN**spirational Scripts, **P**ersonalities and **I**nnovative **R**esearch of **EEE**

## *VISION*

To become a high standard of excellence in Education, Training and Research in the field of Electrical and Electronics Engineering and allied applications

## *MISSION*

To Produce excellent, innovative and Nationalistic Engineers with Ethical values and to advance in the field of Electrical and Electronics Engineering and Allied Areas

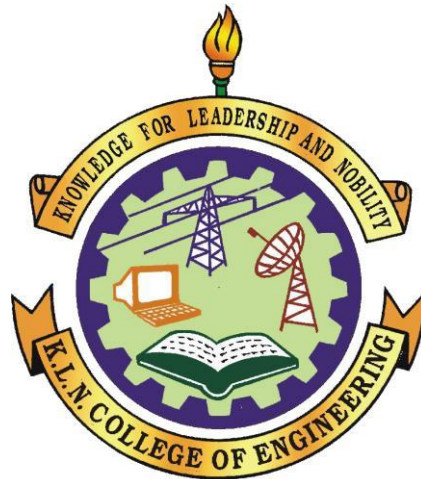

**K.L.N. College of Engineering**

**Pottapalayam – 630 612, Sivagangai District, Tamil Nadu, India**

# INDEX

S.No	Title	Page No
1	Electrical Vehicles Challengers Economical Reform	5
2	Technical Writing for Journal Publication	16
3	Fire Accident Prevention Using IOT Technique in Hospital and Temple	17
4	Examination Reforms& Challengers	30
5	Guidelines for Writing a Research Paper for Publication	32

## MESSAGE FROM HEAD OF THE DEPARTMENT

In this issue articles on the most recent topics presented by the student Electrical vehicles are desired of the future economic of our country.

A Briefly note on this presented opportunity are very high on this field.



Some of the articles guide lines for technical paper written in presentation. Once work will be appreciated only when it is presented well.

As the paper will be presented in the National/International forum, special care should be taking before publishing in the articles. The recent fire accident hospitals and temples required more precaution measure to be taken to safe guards. Our loved only and properties and document protected for long period of time. Examination reforms and challenges will definitely improve the confidence of the student.

**BEST WISHES**

# **EDITORIAL CREW**

## **EDITOR IN-CHIEF:**

Dr. S.M. KANNAN [Professor & Head]

## **EDITOR:**

R.JEYAPANDI PRATHAP [Assistant Professor 2]

## **STUDENT IN-CHARGE:**

S.SOWMIYA (152022/ III Year B Section)

M.YOGESWARI (152067/ III Year B Section)

T.S.RAMYAMEENAKSHI( (152006/ III Year B Section)

K.B.SURIYA NARAYANAN(152063/ III Year B Section)

## **POSTER CREATION:**

M.D. KANAKARAJAN,M.A.,PGDCA [Lab Instructor]

# ELECTRICAL VEHICLES CHALLENGERS ECONOMICAL REFORMS

S.L.OMNATH(152033)/ III YEAR / B

## NEEDS FOR ECONOMICAL REFORMS:

The year 2017 will be remembered as a significant one for defining India's mobility architecture. From big ticket announcements on the marquee Ahmedabad-Mumbai high-speed rail project to Hyperloop, India has seized its moment in the sun to announce big plans for finding next generation transportation solutions.

But nothing has caught the imagination of the industry and policy makers quite like the government's ambitious plans for a mass scale shift to electric vehicles (EVs) by 2030 so that all vehicles on Indian roads by then—personal and commercial—will be powered by electricity. While the transformative push for electric vehicles has become a cause célèbre for India and the world, it presents challenges along with opportunities.

With Volvo's July announcement that it would phase out the internal combustion engine and manufacture only electric or hybrid vehicles by 2019, many believe India's EV moment has arrived. It won't be long before major automakers in India follow Sweden-based Volvo's lead in phasing out internal combustion engines and electrifying their line-ups to meet the 2030 deadline.

## EVS AS A STORAGE

The fates of solar power and electrical vehicles in India are likely to be closely interlinked, given that EVs have batteries that can offer a storage solution to India's clean energy push.

Solar power generated during the day needs to be stored in batteries. The storage capability of EV batteries could help with grid balancing,

complementing the National Democratic Alliance government's push for solar power. With lithium battery prices having nose dived from \$600 per kilowatt-hour (kWh) in 2012 to \$250 per kWh in

2017, the solution is becoming economically viable. The EV industry is betting on a further drop to \$100 per kWh by 2024.

“Another related emerging technology is of electric vehicles that can also double up as a storage device. Suitable application of time-of-the-day tariff mechanisms will be applied to encourage EVs to store-up renewable energy when it is available in excess of demand,” according to India's draft national energy policy.

With plans of reducing the cost of charging stations by half to around Rs1 lakh each, comparisons are being made to the yellow coloured public call office booths which took telephony to India's remote corners in the eighties and nineties.

“By and large, we see electricity emerging as the primary source of energy,” said power and new and renewable energy minister Raj Kumar Singh last month at a conference. “When we were discussing mobility, somebody was telling me that electric mobility is more efficient than mobility by petrol or diesel. The only thing which is required is for the prices of the battery storage system to come down. So, that is a future which I see that gradually we will move towards electric mobility. Now, that will require investments in storage systems (and) in electric vehicle manufacturing,” Singh added.

## CLOSE OF OIL IN INDIA

Policy think-tank Niti Aayog has recommended offering fiscal incentives to EV manufacturers and discouraging privately-owned petrol- and diesel-fuelled vehicles. These are potentially far-reaching moves for India's mobility, energy and environment needs and could spell the end of the internal combustion engine as we know it. India's policy mandarins have also thrown their weight behind EVs, impressed by their 20 moving parts as against 2,000 in traditional petrol or diesel vehicles.

The draft national energy policy states: “EVs are an area of huge interest to India as it holds the potential of reducing the demand for liquid fuel.”

“The advent of EVs will have helped curb a rise in share of oil and environment friendly gas would substitute oil in many uses,” it adds.

## Price factor

Use of lithium-ion battery is expected to show significant rise in days to come with the projected fall in its price.

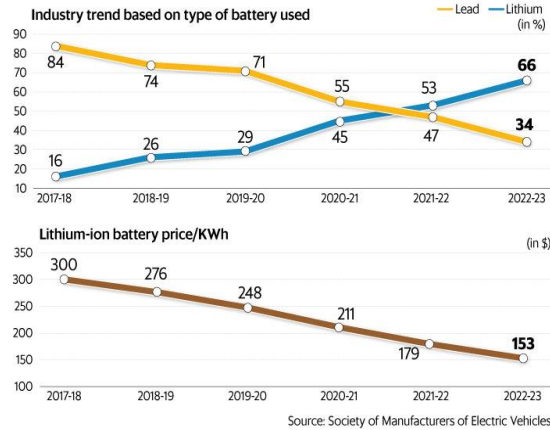

## INDIA'S PLAN

State-run firm Energy Efficiency Services Ltd (EESL) has been tasked with the job of triggering early adoption of electric vehicles. The newly-created firm, which made a name for itself by reducing the price of LED lights for home lighting by 86%, floated a tender for procuring 10,000 electric cars, the largest such procurement in the world. Tata Motors Ltd won the EESL contract, with Mahindra and Mahindra Ltd matching its bid and winning 30% of the order. "There is a need to kick-start the market and that is what we have done with this 10,000 vehicles tender. It's a trigger in many ways," EESL managing director Saurabh Kumar said in an interview before the EV bid results were declared. The vehicles will be procured at a per-unit price of Rs11.2 lakh with the aim of laying the foundation for a mass shift to EVs by 2030. EESL's business model is to make these vehicles available on lease to the government and its agencies for around Rs45,000 per month, which is Rs5,000 less than what is currently paid for petrol and diesel cars. Sending a clear signal that India is firmly moving towards electric vehicles, the goods and services tax (GST) Council has set a tax rate of 12% for electric vehicles, compared with 28% plus cess for petrol and diesel cars and hybrid vehicles.

The Indian auto industry was also warned by the government in September to switch to production of vehicles running on non-polluting alternative fuels or risk being overtaken by inevitable policy change. Ashok Jhunjhunwala, a professor at the Indian Institute of Technology, Madras, who is spearheading the government's EV programme, declined to comment for this article.

## INVESTORS' RUSH

From Finnish state-controlled energy utility Fortum which plans to develop EV charging infrastructure in India, to billionaire Sajjan Jindal's JSW Group which is exploring a partnership with China's Zhejiang Geely Holding Group Co. to make EVs, the list of investors drawn to India's EV sector is quite long.

Swiss stock exchange-listed Leclanché SA also plans to [partner](#) with SUN Mobility for developing battery storage solutions.

From China's Zhuhai Yinlong New Energy Ltd, which plans to set up an EV manufacturing plant in Punjab, to BP Plc, which is planning to leverage its partnership with Reliance Industries Ltd to explore unconventional mobility solutions, nobody wants to be left behind.

"It (EVs) is gaining a lot of momentum. There is a lot of talk," said Malcolm Wrigley, country manager, India, for French energy firm Engie SA, in an interview.

To a question on whether Engie would be interested in setting up EV car charging infrastructure in India, Wrigley said, "That certainly is on the agenda."

Currently, Mahindra & Mahindra Ltd is the only automaker selling a fully electric car in the country, while others including Maruti Suzuki India Ltd and Toyota Motor Corp. offer hybrid versions.

# **ELECTRICAL VEHICLES CHALLENGERS**

## **ECONOMICAL REFORMS**

M .VIGNESH/ II-Year/EEE

### **INTRODUCTION:**

The term motorized transport has never developed without the companion of the term energy. No matter the steam engine in the 18th century or the later invented internal combustion engine (ICE) or the electric motor or hybrid cars, transport development has undergone a process of matching proper energy supplies with updated technologies. Over the past centuries and up to now, ICE has been playing a dominant role in road transport. The use of fossil fuel has within the same period been relied by the modern society. However, being a limited and contested resource, oil has rapidly been explored and consumed, which revealed a day of oil depletion. Due to that the reservation of oil is mostly in the areas that are today politically unstable, and the oil prices are also fluctuating, which is the threat to a large part of the car users. But more importantly, the atmosphere has been severely damaged by CO<sub>2</sub> and other greenhouse gas emissions from ICE Driven vehicles. The impact of the greenhouse gases will increase gradually in the temperature level of the Earth. Wherever we looked, we saw evidence of destruction: melting permafrost, higher sea levels and unpredictable climate changes. "Climate change, which has identifiable potentially catastrophic effects on the environment and human security in the broadest sense, cannot be halted, much less reversed, without the control and reduction of carbon dioxide emissions into the atmosphere".

The introduction of electric vehicles (EVs) has been a proposal to prevent climate change and attempts have been made in several countries during the 1980s and 1990s such as the USA and Denmark. However due to battery technology deficiency, the attempts were unsuccessful and given up. As the oil price increase and the atmosphere is severely damaged, the attempts of reintroducing EVs emerged in recent years in several countries such as USA, Japan, Denmark and China.

### **CURRENT SITUATION OF EV:**

In order to solve energy supply issue, an electric vehicle technological innovation research was carried out. For many years, exploration and practice of the scientists has proved that the electric vehicle system can be improved significantly. This kind of electric vehicle system has been planned as project in some countries. In the future, the environment need suggestions that emissions of vehicle exhaust will decrease in big leaps during the next 50 years. In this point of view, emission goal will be near zero emissions.

### **METHODOLOGY:**

Most of the electrical vehicles were working with the help of the battery energy source or else solar energy source but we will prefer an idea for an infinite energy source (i.e. feedback based energy source for the electrical vehicles). Now the electrical vehicles are working with the help of the motor which requires the continuous energy source that energy source are given by the battery we will prefer the energy source will be produced by the generator instead of the battery. In this case we will not remove battery completely.

The electric dc motor armature shaft was interconnected to the differentiator of the back wheels of car and front wheels does not have any motor system it contains only the braking system alone. Whenever the car is move with the help of the motor the charge of the battery was decreased is this main problem of the EV and recharging time was also much more.

So we have an idea for continuous working of the car motor with the help of GENERATOR BASED FEEDBACK ENERGY SOURCE system. The DC generators are fixed at both front wheels of the car and these dc generators are connected to the battery as well as motor of the car. And which is controlled



automatically with the help microcontroller board when speed variation in the car.

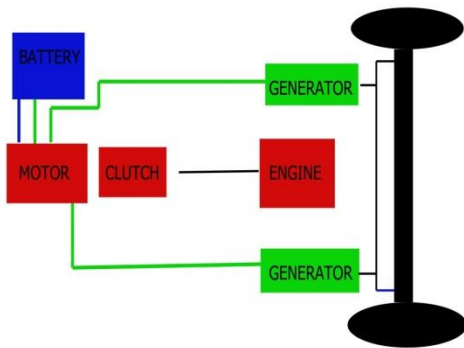

The car was started with help of the battery and drive the car, the discharging level of the battery is depends upon the speed of the motor. In this case the car can't get a sufficient energy supply from the battery due to continuous discharging of the battery. Instead of that we have to use the speed of the car and then converted into the electric source for the car using the dc generator. Whenever the car moves the front wheels of the car also rotates. Armature shaft of the generator also rotates due to which is fixed to the wheels .the generator generates the DC power and it is fed back to the dc motor of the car. The energy source will be continuously flowing to the motor until the car will stop.

By this way we have to reduce the battery power consumption and also maintain the charging level of the car battery. The battery power will be used only when we want to increase the speed of the vehicle and starting purpose

## CONCLUSION:

To sum up, we think that there is a market and economic feasibility of developing EVs in China. With all the driving force on position, what is still missing is much more investment on constructing both renewable energy plants and EVs for the purpose that EV market can be eventually formed.

As we all know, it is the common topic to modernize the society and protect the environment. Here, electric vehicles system is the double-win method relating to this topic. In the last decade, people always thought a lot of economic development and financial benefits. However, they often ignore the energy storage and environment breakage. At the same time, more and more problems came into human's concern, which violates the purpose of sustainable development. Let us think about the electric vehicles system. The development of electric vehicles can offset its dependence on imported oil. The other side, vehicle exhaust is the main greenhouse gas. If we can abase the vehicle exhaust, we can achieve environmental protection. Moreover, energy system is also the main driver to promote the development of EV technologies. At present, gasoline and diesel provide the most of the transport energy. EV can use electricity to provide power for transportation. Electricity has already provided power for some rail network. In future, electricity will be used to charge batteries in fully electric vehicles. The demand for mitigating climate offered by future electricity based EV system would therefore be dependent on the clean energy, such as renewable energy, nuclear energy and coal energy with carbon capture and storage.

# ELECTRICAL VEHICLES CHALLENGERS ECONOMICAL REFORMS

S.SOWMIYA(152022)/III-EEE/B

The structural threat to the energy sector hinges on the continued advancement of electric vehicle (EV) technology and adoption. This supplemental article addresses some of the potential technical challenges for EV adoption which we encountered while researching EVs. As always, when looking at a structural change there is considerable uncertainty about timing and technologies. This supplement is intended for those that may have similar questions about the evolution of EVs or are simply interested in learning more.

## **CAN THE GRID SUSTAIN MASS EV RECHARGING?**

Forecasting the future electricity demand from electric vehicles is difficult because there are many unknowns, including the EV adoption curve, availability of incentives, infrastructure build-out, the price of gasoline and the general health of economies. If all drivers of light-duty vehicles switched from gas to electric vehicles, would electric grids have the capacity to recharge all EVs today? If the switchover was a dramatic one-day event, the answer would likely be 'no'. Luckily, Rome was not built in a day. If all light-duty vehicles in the US were replaced with EVs, they would require about 1,000 Terawatt hours (TWh) of additional electricity per year, or an increase of about one-quarter of our current electricity demand.<sup>1</sup> One TWh is equivalent to the power required to electrify 100,000 homes in the US.<sup>2</sup> An extra 1,000 TWh of demand would be more than enough to overload existing systems.

## **AVAILABILITY OF CHARGING STATIONS**

It's becoming clear that a robust charging network is required to spur greater demand for EV adoption. Research shows some of the top reasons for rejecting EVs are related to charging infrastructure or driving range.<sup>3</sup> Recent projections for global charging-station deployments estimate that public and private installations could grow from around two million in 2016 to over 12 million in 2020.<sup>4</sup> Governments and

automakers around the world have announced commitments to investing in charging infrastructure over the next ten years. While the intra-city infrastructure is being built, the current lack of inner-city infrastructure may not necessarily impede day-to-day requirements of electric vehicles. Given that most one-way commutes to work are less than 50 kilometers and late-model EVs have up to 360 kilometre ranges, inner-city charging stations should not really be a concern. The infrastructure challenge may be more about mindset than reality for day-to-day usage for more than half the population of drivers that live in a single-family detached home. Our society has a habituated reliance on gas stations to fuel internal combustion engine (ICE) vehicles. Therefore, switching to EVs may be more a function of breaking old habits for new. For example, plugging in the EV when at home at night instead of going to the gas station to fuel up. In this instance, consumers can be incentivized financially to change their habits, given that electricity is cheaper per mile than gasoline (approximately 1/10th the cost).

To fuel internal combustion engine (ICE) vehicles. Therefore, switching to EVs may be more a function of breaking old habits for new. For example, plugging in the EV when at home at night instead of going to the gas station to fuel up. In this instance, consumers can be incentivized financially to change their habits, given that electricity is cheaper per mile than gasoline (approximately 1/10th the cost).

## **WILL BATTERY COSTS BE AFFORDABLE?**

Consumers are excited about the prospect of owning an EV (30% of US consumers consider an EV purchase today)<sup>8</sup> but cost is a major deterrent. The battery is the biggest cost. What is interesting, however, is that costs have come down a long way in a short period of time (see chart below). From 2010 to 2016 battery prices fell almost 80%. In fact, the cost curve has beaten expectations as costs slide more quickly than anticipated.

Battery cost is also a major consideration for EV range. As battery prices decline, manufactures and consumers can choose between a lower price and a larger battery. This allows for the option of longer-range vehicles, if consumers require them.

# ELECTRIC VEHICLE CHALLENGE AND ECONOMIC REFORM

MALATHI/EEE/VI-Year

## INTRODUCTION:

Electric vehicles are as a promising way to reduce the greenhouse effect, have been researched extensively. With improvements in the areas of power electronics, energy storage and support, the plug-in hybrid electric vehicle (PHEV) provides competitive driving range and fuel economy compared to the internal combustion engine vehicle (ICEV). Operating with optimised control strategies or utilising the concept of the energy management system (EMS), the efficiency of the PHEV could be significantly improved. In this review paper, the operating process of the various types of EVs will be explained. Battery technology and supercapacitor technology will also be discussed as a possibility to increase the energy capacity of PHEV.

## ELECTRIC VEHICLE:

During the last few decades, environmental impact of the petroleum-based transportation infrastructure, along with the fear of peak oil, has led to renewed interest in an electric transportation infrastructure. Electric Vehicles differ from fossil fuel-powered vehicles in that the electricity their consumption can be generated from a wide range of sources, including fossil fuels, nuclear power, and renewable sources such as tidal power, solar power, and wind power or any combination of those. The carbon footprint and other emissions of electric vehicles varies depending on the fuel and technology used for electricity generation. The electricity may then be stored on board the vehicle using a battery, flywheel, or supercapacitors.

## ADVANTAGES:

Vehicle making use of engines working on the principle of combustion can usually only derive their energy from a single or a few sources, usually non-renewable fossil fuels. A key advantage of hybrid or plug-in electric vehicles is regenerative braking due to their capability to recover energy normally lost during braking as electricity is stored in the on-board battery.

## TYPES OF ELECTRIC MOTORS:

The power of a vehicle electric motor is measured in kilowatts (kW). 100 kW is roughly equivalent to

134 horsepower. Electric motors can deliver their full torque over a wide RPM range so the performance is not equivalent and far exceeds a 134 horsepower (100 kW) fuel-powered motor which has a limited torque curve. Direct current (DC) electricity is fed into a DC/AC inverter where it is converted to alternating current (AC) electricity and this AC electricity is connected to a 3-phase AC motor. For electric trains, forklift trucks, and some electric cars, DC motors are often used. In some cases, universal motors are used, and then AC or DC may be employed. In recent vehicles various type of motors have been implemented for instance .

## CONCEPT OF EV:

EV 'tank-to-wheels' efficiency is about a factor of 3 higher than internal combustion engine vehicles. Energy is not consumed while the vehicle is stationary, unlike internal combustion engines which consume fuel while idling. However, looking at the well-to-wheel efficiency of EV, their total emissions, while still lower, are closer to an efficient gasoline or diesel in most countries where electricity generation relies on fossil fuels. Well-to-wheel efficiency of an EV has less to do with the vehicle itself and more to do with the method of electricity production.

## PARTICULAR EV:

A particular EV would instantly become twice as efficient if electricity production were switched from fossil fuel to a wind or tidal primary source of energy. Thus, when "well-to-wheels" is cited, one should keep in mind that the discussion is no longer about the vehicle, but rather about the entire energy supply infrastructure - in the case of fossil fuels this should also include energy spent on exploration, mining, refining, and distribution.

## MAINTENCE COST OF EV:

The cost of operating an EV varies wildly depending on location. In some parts of the world, an EV costs less to drive than a comparable gas-powered vehicle, as long as the higher initial purchase-price is not factored in . In the US, in states which have a tiered electricity rate schedule, "fuel" for EVs today costs owners significantly more than fuel for a comparable gas-powered vehicle. A 2011 study done by Purdue University found that in California most users already reach the third pricing tier

for electricity each month, and adding an EV could push them into the fourth or fifth (highest, most expensive) tier, meaning that they will be paying in excess of \$.45 cents per kWh for electricity to recharge their vehicle. At this price, which is higher than the average electricity price in the US, it is dramatically more expensive to drive a pure-EV than it is to drive a traditional pure-gas powered vehicle.

**CONCLUSION:**

The objective of a tiered pricing system is to discourage consumption. It's meant to get you to think about turning off your lights and conserving electricity. In California, the unintended consequence is that plug-in hybrid cars won't be economical under this system," said Tyner (the author), whose findings were published in the online version of the journal Energy Policy.

# ELECTRICAL VEHICLE CHALLENGERS AND ECONOMIC REFORMS

A.NACHAMMAI(152005)/ EEE/III-B

## ELECTRICAL VEHICLE :

Electrical vehicle is a vehicle that uses electricity for power instead of using fuels. First of all let me state, that there are many types of electrical vehicles beyond cars, because people are imagined that the synonymous of "ELECTRIC VEHICLE" is "ELECTRIC CARS". But really lots of vehicles can be operated by electricity such as electric trucks, electric buses, electric bikes, electric trains, electric planes etc.,.

Before entering into the topic Let us see **How an electrical vehicle operate:** In both electrical and conventional vehicles, the wheel movement can be obtained from the motor but the only difference is the input to the motor. In conventional vehicle the input to motor is any of the non-renewable sources like petrol or diesel or gas but the electric vehicles uses electricity stored in a battery to power the electric motor and turn the wheels.

## OPPURTUNITIES FOR ELECTRICAL VEHICLES :

Fueling with electricity offers some advantages that are not available in conventional internal combustion engine vehicles. The main drawback of our combustion engine vehicle is that the fuel is very expensive and it is not an affordable one. This reason made a great opportunity for electrical vehicles. But in electrical vehicle we can charge it as like our smart phone . we can charge it when we get home and it is to ready for use the next morning . Since the electric grid is available anywhere, there are a variety of options for charging at home, at work or on the road. Electric vehicles are eco friendly as they run on electrically powered engines. So, it does not emits toxic gases or smoke in the environment as it runs on clean energy source. The batteries used for charging the electric

vehicle can be charged by using solar panels or wind mills. In this case fuel is full free and it is completely free from pollution also. In case an accident occurs, the supply from the battery is cut off immediately even after the airbags get open. In future we may add a feature that in case of accidents the message has to send to the emergency ambulance and to his /her family members from the car itself Earlier electric vehicles are expensive but now because of the technological advancements, the cost had somewhat gone down

## CHALLENGES FOR ELECTRICAL VEHICLE:

- Lifetime of electrical vehicle should be greater than our existing ones.
- It can able to provide extra mileage as much as possible.

Electric fuelling stations are still in the development , so at present it can be used locally. We have to find an alternate solutions for charging the vehicles while going for a long trip. Electric vehicles need improvement in the field of their speed, because most of the vehicles have range about 50-100 miles and it should be charge again. The speed range is a very big challenge for electrical vehicles. The charging time of electric vehicle is also a big issue. Depending upon the usage it requires replacement of batteries. Countries which are lagging in power generation cant prefer electric vehicles Finally I would like to end up this article by a line "WE WILL NOT STOP UNTIL EVERY VEHICLE ON THE ROAD IS ELECTRIC "

# ELECTRICAL VEHICLES CHALLENGERS ECONOMIC REFORMS

MADHUMETHA(152014)/ EEE/III-B

## INTRODUCTION:

India's population is expected to surpass that of China's in 2030, making it the most populous country in the world. High economic growth rates and the impacts of globalization have concentrated prosperity in urban centres resulting in sprawl and auto-mobilization. Within 15 years the population residing in urban areas is expected to double to over 700 million due to distressed rural to urban migration and other factors. This will place additional pressures on urban infrastructure, which is already overburdened. Projections indicate that by 2021 India will have the largest concentration of megacities in the world with a population exceeding 10 million. Out of a total of 88 cities, with a population of more than half a million, only 28 have any formal public transportation system. In most cases, the existing public transport systems are ageing and stretched beyond capacity, as the demand for public transport services outstrips supply, both qualitatively and quantitatively.

## EVOLUTION OF ELECTRICAL VEHICLES:

The growth of the Indian economy is impacted by the price of oil imports, which tends to be extremely volatile and sensitive to economic and political shifts. The transport sector is a key consumer of oil and oil products. More than 50% of the oil consumption in India occurs because of transport-related activities. The World Energy Outlook has estimated that most of the increase in oil consumption by 2030 in India will be driven by light-duty vehicles, mainly passenger cars – growing at an annual rate of approximately 10%.

Until recently Governments and businesses have ignored the phenomenon of 'peak oil'. Peak oil refers to the 'point at which the maximum rate of global oil extraction is reached'. However, there has been growing acceptance of peak oil in the public domain, where both Governments and businesses have been exploring alternative sources of energy supply, primarily renewable sources like solar, wind, hydro, geo-thermal and nuclear energy. The oil industry is beginning to realize that we have

crossed “the era of easy oil, (and) in the future oil will be dirtier, deeper and far more challenging (to extract)”. Technologies that have the potential to phase-out oil dependent forms of transportation should be actively pursued to gauge their feasibility. Considering an oil constrained future and the high emission levels associated with the transport sector, it is therefore important to reduce the use of petroleum dependent private vehicles in the country.

## ELECTRIC VEHICLES (EV)

EV's utilize electric motors to induce propulsion. The key differentiator between EV's and conventional ICE vehicles is that the electricity that they consume can be derived from different sources or a combination of energy sources, particularly renewables such as solar and wind energy. Electric vehicles are only as

'green' as the energy sources used to charge them. Charging EV's in India remains a challenge, where 60% of electricity is generated from fossil fuels fired coal power plants. Electricity can be transmitted to EV's wirelessly through induction or directly using an electrical cable. EV's utilize on-board batteries to store electricity. Unlike ICE's, EV's are capable of regenerative braking whereby they are able to recover the energy that is lost during braking as electricity that is then stored back into the on-board battery. They do not have any tail-pipe or evaporative emissions and are virtually maintenance free. There has been a renewed interest in EVs as a solution to address the emerging concerns around energy security and climate change.

The Electric Vehicles will create value in three dimensions: –

**ENVIRONMENT:** As the share of miles driven by EVs increases, urban mobility emissions will decrease progressively; electrification combined with a clean energy mix and optimized charging

patterns will further reduce emissions, improving air quality and benefiting human health, with a much-decreased ecological footprint.

**Energy:** EVs are a relevant decentralized energy resource (DER), providing a new controllable electricity demand, storage capacity and electricity supply when fully integrated with grid edge technologies and smart grids. Smart charging will create more flexibility in the energy system, improving stability and optimizing peak-capacity investments. This will also open the door to broader energy efficiency services.

**Mobility:** EVs will become more affordable than vehicles powered by internal combustion engines (ICEs) as the cost of batteries declines. Smart-charging services will reduce charging costs (for example, by charging when energy prices are low, if dynamic pricing is implemented), and new revenue streams for fleet operators, who will be able to provide ancillary services to energy markets

#### **CONCLUSION:**

Whether or not electric vehicles will become commonplace in the global mass-market or will dominate in the alternative vehicle segment will depend on several success factors. However, the uniqueness of the success factors differs from country to country and OEM to OEM. All in all one can say that today the automotive industry without EVs is no longer imaginable. The fulfilled success factors offer a breeding ground for the EV market. Therefore, EVs are rapidly becoming a mainstay in vehicle product lines. Already today all major OEMs offer at least one EV. More models will follow in the near future. As a consequence, OEMs are confronted with a growing challenge as how best to succeed and to become market leaders in the EV market.

# TECHNICAL WRITING FOR JOURNAL PUBLICATION

PREETHI/IV-Year/EEE

## **DISCRIPTION:**

The Journal of Technical Writing and Communication (JTCW) is one of several prestigious international scholarly journals in the field of technical and professional communications.

Published quarterly, JTCW strives to meet the diverse communication needs of industry, management, government, and academia. For over forty years, the Journal has served as a major professional and scholarly journal for practitioners and teachers of most functional forms of communication.

JTCW's mission is to publish peer-reviewed cutting edge research on communications-related issues, as well as relevant materials on the teaching of technical and professional writing and reviews of recently published books.

## **AIMS:**

- Our purpose is to publish a thoroughly solid journal that performs as the needed bridge between academia and the world of practitioners.

## **TECHNIQUES:**

- Good technical writing is concise, focused, easy to understand, free of errors, and is audience-based.
- Technical writing requires a writer to extensively examine his or her audience. A technical writer needs to be aware of his or her audience's existing knowledge about the material he or she is discussing as the knowledge base of the writer's audience will determine the content and focus of a document.
- Technical writing must be accurate. A technical writer, after analyzing his or her audience, knows what they are trying to communicate.

## **TECHNICAL DOCUMENTS:**

- Technical writing covers many genres and writing styles depending on the information and audience. Technical documents are not solely produced by technical writers. Almost anyone who works in a professional setting produces technical documents of some variety.
- Some examples of technical writing include: Instructions and procedures, proposal, email, letters, press release, description, resume and job application, etc.

## **SUBMISSION GUIDELINES:**

- Authors are responsible for all statements made in their work and for obtaining permission from copyright owners to use a lengthy quotation (exceeding the limits of fair use) or to reprint or adapt a table or figure published elsewhere.
- Authors should write to the original author(s) and publisher of such material to request nonexclusive world rights in all languages for use in print and non-print versions of the present article and in all future editions.
- Provide copies of all permissions and credit lines obtained.



# FIRE ACCIDENT PREVENTION USING IOT TECHNIQUES IN HOSPITAL AND TEMPLE

R.RAMYA(152030)/III YEAR/EEE

Now a days many fire accident occur in the hospital. For examples, a huge fire tore through a South Korean hospital Friday killing at least 41 people, the government said, in the country worst blaze for 15 years. More than 80 others were hurt in the fire, which comes just weeks before thousands of athletes and foreign visitors are expected in the country for the winter Olympics.

## SMART HOSPITAL BUILDING AUTOMATION SYSTEMS:

Smart buildings aren't just for factories and warehouses. As a modern medical facility, you have an expectation from patients and the bystanders to utilize the latest technology in security and hospital building management. A lot of efficiency and cost savings are at stake if an efficient building automation system is not implemented. We have built our own energy efficient and low maintenance wireless sensors modules to help hospitals adopt industry standard automation solutions.

Temperature and humidity controls are critical when it comes to critical medical procedures, medical devices, and even patient care. Access control, video surveillance, lighting, HVAC units, and other building management systems need to all be streamlined so that they may be easily monitored and controlled. We can integrate [building automation systems](#) for medical facilities who want to offer patients the best care and security on the market to help you become a smart hospital your patients can trust.

## SMART HOSPITAL – ENERGY MANAGEMENT:

With a large area to maintain, finding ways to save energy around your medical facility can be challenging; especially with a commitment to excellence in patient care. Unplugging life-saving medical devices and equipment isn't an option – but

adjusting temperature and lighting in a large facility is one way to cut costs and save energy. A hospital building automation system connects all of the mechanical and lighting systems in your hospital and can adjust based on preferred settings. **Use cases of SMART HOSPITAL:**

- PIR motion detectors
- Reed Switch for door opening and closing alerts
- Light bulb dimmer controls
- Glass break in detector
- Smoke detection to alert possible breakout of fire
- CO and CO2 detection
- Intrusion detection
- Combustible gas detection
- Indoor air quality monitoring
- Individual equipment energy monitoring
- Temperature and humidity monitoring in operation theatres, laboratories
- Tracking and locating wheelchairs, portable gadgets etc
- Condition monitoring key equipment such as air conditioners, transformers.

## FIRE ACCIDENTS PREVENTION IN TEMPLE:

Fires are one of the most widespread cause of deaths by accident. Instant alerting to the fire department is necessary to ensure immediate action. Every minute can save many lives in such situations. So here we

propose an IOT based automatic fire department alerting system that instantly and automatically alerts the fire department the fire department and informs about the situation so that immediate action can be taken.

The system uses fire sensor along with PIR sensor to efficiently detect fires and alert fire department over IOT. We use an arduino in order to check if a sensor is triggered. Then it reconfirms if it really is a fire outbreak using temperature sensors in order to confirm of fire outbreak. The system now uses a WIFI connection to access IOT server and transmit data about this incident over internet. As soon as IOTGECKO system receives the sensor data it checks the device id data was sent from and displays device id.

The system now displays the fire incident with alarm buzzer in the fire department over internet so that the fire department personnel are alerted about the incident to take necessary action.

# **FIRE ACCIDENT PREVENTION USING INTERNET OF THINGS**

N. AISWARYA (152037)/ EEE/III-YEAR/A

## **INTRODUCTION**

Prevention of fire and fire risk level control difficulty is increasing day by day. special attention is given to improve the science and technology in resisting fire disasters. They are concerned about the application of new technology such as IoT and wireless sensor network in fire-fighting and monitoring field. IoT is very suitable for fire-fighting with wide scope along with wireless sensor network (WSN). IoT has high degree of intelligence for maintaining many product categories, quantities, complex fire danger factors and large range of equipments for fire monitoring and fighting.

## **REQUIREMENTS OF NEW FIRE FIGHTING SYSTEM:**

The new modern fire monitoring system is based on wireless sensor network in combination with Internet of Things. Because of modern advanced technology, the system minimize the losses due to fire. Sensors detects the fire condition and transfers the data to the system. Fire brigade and building owners can do the interactions with the system. All the data from the sensor nodes located in the buildings are provided to the users. The historical data reference from building data base server provides final useful response mechanisms. The users can communicate with the system through different ways to monitor and control the

environment and get more information about it. Wireless sensor network is communicated with the base station or computer system through RS232 serial port. The fire department or house owner or any attention need public persons will get information through PC Ethernet port. The communication is possible with the other locations in the building through web access parameters by this Ethernet port. GSM interface with short messages and WIFI interface for WIFI camera for video transmission.

## **DESIGN REQUIREMENTS OF IOT SYSTEM FRAME WORK FOR FIRE MONITORING:**

IoT is a network of linking things through sensors and communication equipment, linking things among themselves and finally linking between people and things. In IoT technology, RFID (Radio Frequency Identification), wireless sensor network, pervasive computing, cloud computing, real time monitoring and other technologies are integrated to realize intelligent real time monitoring, management and control of fire. The fire monitoring IoT system frame is planned in accordance with the requirement of fire prevention and control, firefighting, emergency rescue and so on. It is planned to the technical characteristics of IoT and the need of fire monitoring. The IoT system frame for fire monitoring adopts layered structure. This structure includes sensing layer, transport layer, service layer and application layer.

## **SENSING LAYER:**

This layer is mainly used for complete collection of object and environment information. For collecting real time information about various objects using sensors, video, RFID and other technologies involved in fire fighting safety management. Intelligent equipment, sensors and RFID are useful for collecting information such as people, events, environments, materials, firefighting products, fire-fighting facilities and fire-fighting equipment. The collected information is communicated layer by layer, so sensing and control of fire event can be realized in real time.

## **TRANSPORT LAYER:**

It is used to realize the transmission of sensor information to different networks. The proper transmission and access methods are selected depends on different situation such as Internet, LAN, mobile network and police special network etc. It

ensures the proper information transmission and achieve data exchange between different objects and platforms.

**SERVICE LAYER:**

This layer is mainly used for data storage, integration and interface of heterogeneous networks, data mining and visualization of services for different information resources. It supports reliable platform for service management. It ensures the establishment of firefighting safety application. It manages network equipment, converting information, integrating business information and device information.

**APPLICATION LAYER:**

This layer is used for sharing information, integration of user, intelligent analysis and process control for firefighting IoT. It provides application services for service providers, manufacturers, intermediates, government institutions, fire brigade, social units and family. Finally it supports fire-fighting and monitoring business work.

The IoT firefighting application service includes five systems. They are

1. Fire-fighting product identification system,
2. Fire-fighting facility monitoring system,
3. Hazard source monitoring and warning systems,
4. Firefighting equipment and material monitoring system and
5. Emergency field management and control system.

Implementation of the IoT function for fire monitoring:

In WSN, the wireless sensor network fire monitoring system is mainly used for the control of entire system related with fire monitoring operation. The system is developed to perform the following operations.

1. The node will read the building parameters from the fire wireless sensor network.
2. It operates the fire alarm of the building.
3. It process the collected data and finds abnormal by the algorithm related.
4. It displays the read data and results measured by the node.
5. Based on results and measurements the system makes the appropriate response mechanisms.
6. It works and correlates with fire brigade department, administrators, house owners.
7. The system interacts simultaneously with different types of users.

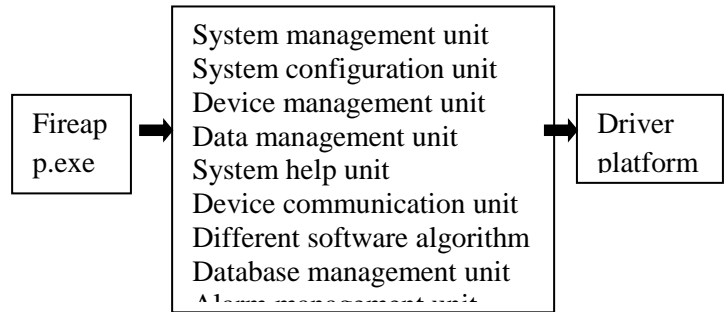

8. The measurement data received by the computer system from sensor node also periodically saved in the database server in the building.

Fig: Fire prevention system software design

**FUNCTION REALIZATION:**

There are mainly three parts of core functions.

1. Analyzing the data from database for the various parameters of fire sensors, appropriate algorithm for its storage, processing and judgment of fire.
2. Fire actions according to plans made for dealing with unusual situations.
3. Provides the user interface functions.

System software is divided in the 3 layers. The first layer is data analysis layer. This is responsible for the data base via serial port to transform into parameters data such as temperature, humidity and image. It is used to maintain classification table for easy transporting query. The second layer is business layer. It is the core of the program. It is used to process the obtained data using different variety of algorithms and based on results the arranged plan is implemented. The third layer is user interface interaction layer. It is used for maintenance of user interface and displays sensor information for fire status monitoring.

**FUZZY LOGIC ALGORITHM:**

The characteristics of fuzzy logic algorithm is based on information fusion. This analyzes and synthesizes multi sensors or multi sources of data under certain criteria to complete data processing for decision making and task estimating. The algorithm fuse fire parameters of multi sensors for determining fire occur or not according to different kinds of fire parameters. This method overcome the limitation of

using single sensor. This algorithm effectively improves the reliability and reduces the rate of false findings. The algorithm of multi parameter on the fire source localization and different analyze can be done from different fire fighting nodes quickly and accurately decide fire sources according to fuzzy methods and track the trends of fire. The faulty node is found based on received signal strength indication method. Different fire alarm signals for different fire fighting scheme.

#### **CONCLUSION:**

Firefighting IoT standard system construction can be accelerated, and nationwide IoT platform can be constructed by actively carrying out system integration and information sharing of fire-fighting remote monitoring system. The IoT technology improves the fire-fighting safety management work from traditional fire-fighting to modern fire-fighting. It promote army construction development, full efforts to maintain firefighting safety. It can effectively protect people's lives and ensure property safety.

# FIRE ACCIDENT AND PREVENTION USING IoT TECHNIQUES IN HOSPITAL AND TEMPLE

M.KEERTHANA/EEE/IV-Year

## PROBLEM STATEMENT:

The problem statement includes improving the quality of data acquisition about distraction-related crashes along with better analysis techniques. By analysing the understanding of the extent and nature of the distraction problem. The main aim is to reduce the driver workload associated with performing tasks using both built-in and portable in-vehicle devices via limiting the visual and manual demand associated with in-vehicle device interface designs.

## BLOCK DIAGRAM:

The Block diagram of proposed prototype consists of the following Components :

1. LCD Display
2. DrowseSensors (IR sensors)
3. LM358 Comparator
4. NXP RD25 (8051 Microcontroller)
5. Vibrator
6. Engine Speed Controller
7. Analog to Digital Converter (ADC)
8. Gravity Sensors (3-axis accelerometer)
9. GSM & GPRS Module ( Mobile phone)
10. Power Supply ( 12V 2Amp. DC+ SMPS )

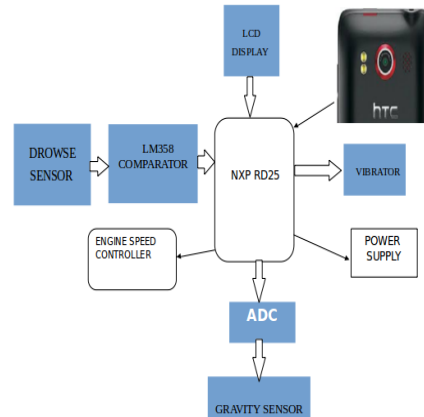

## DESCRIPTION:

The process of working of above block diagram is explained as follows. This project involves measurement of eye blink using IR sensor and head movement using accelerometer. The IR transmitter is used to transmit the infrared rays in our eye. The IR receiver is used to receive the reflected infrared rays of eye. If the eye is closed then the output of IR receiver would be high ,otherwise the IR receiver output is low. To know whether the eye is in closing or opening position. The output is provided to a logic circuit for alarm indication and status will displayed on LCD display. Accelerometer is placed on driver fore-head it measures tilt angle of the drivers in vertical either forward or backward direction and left or right direction from the driver knee. If tilting angle exceeds certain threshold range, This output is give to logic circuit to indicate the alarm and status is displayed.

## **CONCLUSION:**

Majority of portable devices are aimed at providing unlimited access to internet services for data storage and synchronization with other remote devices. Hence, there is a need of faster data acquisition and quick decision making of embedded computing system for real time applications for making vehicles safe, automatic, responsive and intelligent. Interfacing of simple sensors to various micro-controller platforms enables the ease of regulating the embedded system at a sophisticated levels of automation and mediating the sensor information over a smart grid enables large amount

of data acquisition for taking accurate decisions over the emergency conditions. Further, the development of smart grids fascinates the overall process of communication between human and machine rather than machine to machine communication. Hence, IoT can revolutionize the way embedded systems interact and respond for variety of applications especially in case of vulnerable night drivers by monitoring the state of their drowsiness for a quick, safe and effective response for a safer road travel.

# FIRE ACCIDENT PREVENTION USING IOT

## TECHNIQUES IN HOSPITALS AND TEMPLES

M.SOWMIYA (152080)/EEE/III-year 'B'

**INTRODUCTION:**In the field of natural and man-made disasters, fire has played a predominant role. The extrinsic effects of disasters caused by fire have progressively changed over the centuries, especially in the twentieth. As a result, owing to industrial, technological, and military development, there has also been a rapid change in the modalities and numbers of burn injuries. So, in this article there are some preventive measures for the fire accidents in temples and hospitals using IoT based techniques.

**IOT BASED FIRE ACCIDENT PREVENTION IN HOSPITALS:**The phrase "Internet of Things" was coined in 1999 in response to a supply chain challenge that was solved through the use of a microchip and a radio receiver that tracked a popular cosmetic product's inventory status. For solving this problem "IoT based patient monitoring system" & "IoT based alarm system" will become a solution. In basic terms, IoT gives things from cars to medical devices to building systems the ability to store and share valuable information through the use of data-capturing sensors and radio-frequency identification (RFID). "As patient monitoring expands to the home and use of wearable devices, hospitals, clinicians' monitoring of chronic conditions and incorporation of predictive analytics will increase demands on facility infrastructure and data centre requirements".



As challenges are met and managed, which sources say they are confident will occur in good time, the IoT will create the promise of improved health care. "All these systems are going to have an incredible impact on care efficiency and without

spending a lot of extra money". "We just need to be intelligent about how we integrate them."

### FIRE ACCIDENT PREVENTION IN TEMPLES:

**Robotic Response:**In the near future, IoT may even allow for the addition of robotic scouts to clear the way, mark out safe and dangerous rooms, and identify fire victims in need of rescue. In some cases, these scouts may be able to arrive on scene faster than humans, cutting down response times still further. Likewise, these robots could be combined with mapping technologies and heat sensors or even deployed with oxygen resupply for victims and fire-fighters trapped inside a burning building. A recent incident occurs in world famous **Meenakshi Amman temple**, A major fire broke out at Tamil Nadu's Madurai Meenakshi Amman temple complex on Feb 3 2018 . More than 30 shops were gutted in the fire. The fire officials say that the fire started at a toy shop inside the thousand pillar hall near the east tower of the temple around 10pm.

It took 60 fire personnel about five hours to contain the fire. Devotees say there were no fire extinguishers or fire safety systems in the temple. The incident was waiting to happen amid demands to remove shops from the temple complex. Hence, by installing the modern fire safety system with sprinklers on temples thousands of life has to be saved in addition to our tradition and culture.

"Any sufficiently advanced technology is indistinguishable from magic"

Connectivity with an **IoT based building automation system (BAS)** is a key feature of the latest fire safety systems in hospitals. As they continue to evolve, these systems are able to gather and share data, which helps to alert individuals to potential fire safety issues within health care facilities.



# **FIRE ACCIDENT PREVENTION USING IOT TECHNIQUE IN HOSPITAL AND TEMPLE**

UMA MAHESWARI/III/EEE-B

## **FIREFIGHTING AND MONITORING SITUATIONS**

Fire-fighting and monitoring situations are very serious today. Public security keeps on insisting in increase of technology in firefighting and monitoring. They give special attention to improve the science and technology in resisting fire disasters. They are concerned about the application of new technology IoT is very suitable for fire-fighting with wide scope along with wireless sensor network (WSN) IoT technology is combined with fire fighting for hazard source monitoring, fire monitoring, fire-fighting rescue, fire early warning, prevention and early disposal. It is used effectively to enhance the fire brigade fire frightening and emergency rescue capabilities.

## **CAUSES OF FIRE ACCIDENTS**

### **FIRE IS A GOOD SERVANT BUT A BAD MASTER**

Fires accidents are becoming more series because of bigger building density and higher urban buildings. Accidental fires caused 6% of all unnatural deaths in India. Exploding cooking gas cylinders and stoves accounted for nearly one-sixth of all deaths from accidental fires between 2010 and 2014, with a total of 19,491 deaths. Electrical short circuits killed 7,743 people over the same period. Fire accidents kill 54 people daily in India[1] and direct property losses are unknown. In order to protect the people and secure the properties from fire, it is necessary to design good real time high reliable fire monitoring system. There are lot of disadvantages in the available fire

## **IOT SYSTEM FRAME WORK FOR FIRE MONITORING**

**BIG OR SMALL FIRE SAFETY FOR ALL:**

IoT is a network of linking things through sensors and communication equipment, linking things among themselves and finally linking between people and things. In IoT technology, RFID (Radio Frequency Identification), wireless sensor network, pervasive computing, cloud computing, real time monitoring and other technologies are integrated to realize intelligent real time monitoring, management and control of fire. The IoT system frame for fire monitoring adopts layered structure. This structure includes sensing layer, transport layer, service layer and application layer.

## **IOT FUNCTIONS IN WSN**

### **GET SMART USE SAFETY FROM START**

The wireless sensor network fire monitoring system is mainly for the control of entire system related with fire monitoring operation. The system is developed to perform the following operations. 1. The node will read the building parameters from the fire wireless sensor network. 2. It operates the fire alarm of the building. 3. It processes the collected data and finds abnormal by the algorithm related. It displays the read data and results measured by the node. Based on results and measurements the system makes the appropriate response mechanisms. It works and correlates with fire brigade department, administrators, house owners. The system interacts simultaneously with different types of users. The measurement data received by the computer system from sensor node also periodically saved in the database server in the building.

## **FIRE-FIGHTING EQUIPMENT AND MATERIAL**

### **MONITORING SYSTEM**

### **FIRE CONTROL SYSTEM IN HOSPITALS**

## **NO SAFETY KNOW PAIN.KNOW SAFETY NO PAIN**

Although fire alarm systems have changed little in the past few years, innovations such as wireless fire alarm devices and enhanced audio for staged or mass evacuation are now available to enhance performance. “As camera prices come down and many more are deployed, one of the most exciting opportunities is alarm verification for fire alarms,” Tamper explains. “We can automatically bring a live video to operators’ attention when an alarm is activated to help determine whether the activation is real or triggered when there is no actual emergency.”

### **ALERT TODAY ALIVE TOMORROW**

Hospitals pose many challenges to vendors. One of the big issues for fire protection in hospitals is the need for quick assessment and response to emergency events. Because of non-ambulatory occupants, hospitals must focus on a defend-in-place versus an evacuation strategy, making rapid response critical.

Other considerations include ongoing surgical procedures that can’t be interrupted, critical assets such as life-saving and life-support equipment, labs

with significant quantities of flammable or hazardous chemicals, and hazardous materials storage.

Technologies that enable targeted communications — such as display boards that provide message alerts or addressable speakers that deliver a message to a specific area within a facility — can improve fire safety in health care environments.Red Hawk installed and monitored a negative air system to draw contaminants into the work zone and away from patient areas by using HEPA filters to capture particles.

## **CONCLUSION**

Fire fighting IoT standard system construction can be accelerated, and nationwide IoT platform can be constructed by actively carrying out system integration and information sharing of fire-fighting remote monitoring system. The IoT technology improves the fire-fighting safety management work from traditional fire-fighting to modern fire-fighting. It promotes army construction development, full efforts to maintain firefighting safety. It can effectively protect people's lives and property safety. This paper discusses about the design concept

# **FIRE ACCIDENT PREVENTION USING IOT IN HOSPITAL AND TEMPLE**

N.ISWARIYA(152304)/III/EEE/A

## **INTRODUCTION**

With the advancements in the day to day life, fire-safety has become one of the primary problems. Fire hazard are fatally dangerous and denigrating regarding business and home security, further more devastating regarding human life. The obvious way to minimize the kind of loss is respond to these emergency situations as quickly as possible. Thus, at present there is a huge demand and requirements for standalone autonomous flame detection techniques. These kinds of Techniques

render the operations involving flame quenching. These particular frameworks, outfitted with Smoke, Temperature and Pyro -electric detectors can easily identify the troublesome random predicaments, because it is Equipped with the aid of control mechanism which can instantly warn pertaining to venture through steps with ease. In these fatal predicaments, earlier detection effectively combined with quick warning system will probably produce lesser loss regarding property and life.

**OBJECTIVE:** This paper gives an overview of exiting fire –detectors types which can be comprehend to one hundred percent completion combined with the process connected with economical, portable, reliable microcontroller dependent programmed open flame alert system as slightly careful almost a little flames happening in residence as well as professional areas are monitored and controlled. Keywords: Arduino, Flame Sensor, GSM/GPRS, Smoke sensor, Temperature sensor

## **SOFTWARE EMPLOYED:**

To Program ATMEGA328P at first we need to burn the boot loader of the new ATMEGA328P utilizing ArduinoUNOR3 software programmer.

The association is demonstrated as follows:

**ALERT:** Ensure developer is not associated with the outer power supply, as they sustain through the USB link associated with your PC and circuits required ATMEGA328P have managed +5v supply. Then this frame work

Is prepare to blaze the boost loader , to do this action simply open IDE on computer then upload configuration code which is consists of two different codes named “optiLoader.h” and “optiLoader.pde”. GPRS(General Pocket Radio Service) is an information carrier administration bundle based remote correspondence benefit that is conveyed as an overlay system for GSM, CDMA and TDMA(ANSI-136) Systems. GPRS first radio packet applies to exchange client information bundles productively between versatile station and GSM systems outer bundle information is partitioned into packets that are transmitted independently and afterward reassembled at the less than desired end. GPRS underpins internet pioneer packet based world.

## **CONCLUSION**

The developed fire alarm system is simple but it really offers vast division of APP in residence and also manufacturing basic safety, specifically in creating nations around the world. Employing these method fast and also reputable warnings can be performed for us to trigger preventative methods to avoid risk associated with life and property. This can be utilized to distinguish propane burnable as methane ,LPG and so on. Frame works planned with scope up to 100 square meters, Just using so as to measure area a link of classification 6 cable connection seeing that facts brand. This can installed in several modules, each of them for one floor or may be for unit.

# **FIRE ACCIDENT PREVENTION USING INTERNET OF THINGS**

### **INTRODUCTION:**

Fires are one of the most widespread cause of deaths by accident. Instant alerting to the fire department is necessary to ensure immediate action. Every minute can save many lives in such situations. So here we propose an IOT based automatic fire department alerting system that instantly and automatically alerts the fire department and informs about the situation so that immediate action can be taken. The system uses Fire sensor along with PIR sensor to efficiently detect fires and alert fire department over IOT. We use an arduino uno in order to check if a sensor is triggered. Then it reconfirms if it really is a fire outbreak using temperature sensors in order to confirm of fire outbreak. The system now uses a wifi connection to access IOT server and transmit data about this incident over internet. We here use IOTGecko platform to develop the web based IOT interface. As soon as IOTGecko system receives the sensor data it checks the device id data was sent from and displays device id(which will be named after area/flat id). The system now displays the fire incident with alarm buzzer in the fire department over internet so that the fire department personnel are alerted about the incident to take necessary action.

### **IOT IN HOSPITALS FOR HEART DISEASES:**

These days we have an increased number of heart diseases including increased risk of heart attacks. Our proposed system users sensors that allow to detect heart rate of a person using heartbeat sensing even if the person is at home. The sensor is then interfaced to a microcontroller that allows checking heart rate readings and transmitting them over internet. The user may set the high as well as low levels of heart beat limit. After setting these limits, the system starts monitoring and as soon as patient heart beat goes above a certain limit, the system sends an alert to the controller which then transmits this over the internet and alerts the

doctors as well as concerned users. Also the system alerts for lower heartbeats. Whenever the user logs on for monitoring, the system also displays the live heart rate of the patient. Thus concerned ones may monitor

heart rate as well get an alert of heart attack to the patient immediately from anywhere and the person can be saved on time.

### **IOT Based ICU Patient Monitoring System:**

Intensive Care Unit or ICU is where the patients who are critically ill are admitted for treatment. For such critical conditions the Doctors need to have an all-time update patient's health related parameters like their blood pressure, heart pulse and temperature. To do manually, this is too tedious a task and also for multiple patients it becomes close to impossible. For this type of situations this IOT based system can bring about an automation that can keep the Doctors updated all time over internet.

IOT Based ICU Patient Monitoring System is a Raspberry Pi based system which collects patient's information with the help of few sensors. It uses Wifi module to communicate this information to the internet. There is this Blood pressure and heart beat monitor module electrically connected to the system and physically to be worn by the user. On the press of button, the sensor senses the blood pressure in systolic and diastolic along with the heart beat and sends it to the central controller. The Temperature sensor senses the temperature of its ambience, so when this sensor is in close proximity of the user it reports the users' body temperature. Thus, the doctor can get access to these vital parameters pertaining to the patients' health over the IOT Gecko web interface from anywhere over the world. In this way IOT Based ICU Patient Monitoring System is an enhanced system that helps in monitoring ICU Patients without any manual intervention.

### **IOT FOR THEFT DETECTION IN TEMPLES AND PUBLIC PLACES:**

Here we propose IOT based theft detection project using Raspberry Pi where we use image processing on live video to detect theft using motion and also highlight the area where motion occurred. This system secures offices/homes from theft by instantly detecting theft as well as allowing user to view the

theft details thereby highlighting the theft details and saving the video in a usb drive. In this system we use a camera along with raspberry pi along with a circuit with LCD display IR for night vision and USB drive for storage. The system is powered y a 12V power supply. As soon as camera motion is detected in camera footage the system uses image processing to detect exact area of motion occurrence and highlights it accordingly. The system now transmits the images of the occurrence over IOT to be viewed by user online. We here use IOT Gecko to develop the online system. Also it stores the footage in a USB drive for further reference. The user can now decode the data sent online using IOT Gecko IOT system to view the images of the motion occurrence live remotely over internet. Thus the system provides an innovative approach to theft detection using IOT.

#### **DISCUSSION:**

Fire in itself is a word that describes loss and hazardous situation. There is an immense need of implementation of automatic fire detecting system to protect lives and assets from fire hazards. In this paper some fire protection systems are explained. Use of real-time control via the Internet or wireless network will extend the monitoring and control of fire safety systems outside of the building. The status of the fire safety system and other building systems can be monitored at any time and from anywhere via the Internet or wireless network. The fire safety systems located in many buildings will be controlled from one central facility office. This will increase the efficiency and reduce costs for building management operations, more efficiently discriminate between fire and non-fire threats and increase the time available for property and life protection. 29

# EXAMINATION REFORMS&CHALLENGES

B.S.KIRUBA BABU,K.KRISHNAKANTH, (142031,142074)/IV-Year/EEE/B.

## INTRODUCTION:

Exam Reforms. Education is a continuous and life long process of learning. The quality of education is intrinsic to the examinations. Ideally the examinations are meant to test the higher abilities, application of knowledge, creative thinking and problem solving.

## OBJECTIVES:

The relationship between examinations and standards of teaching and learning are intimate. Improvement in any one of these aspects results in improvement of other aspects as well. Therefore, the objective of examination reform is to make it an instrument of good education.

- (a) The elimination of excessive element of chance and subjectivity;
- (b) The de-emphasis of memorization;
- (c) Continuous and comprehensive evaluation that incorporates both scholastic and non-scholastic aspect of education, spread over the total span of instructional time;
- (d) Effective use of the evaluation process by teachers, students and parents; as well as
- (e) The introduction of concomitant changes in instructional materials and methodology;
- (f) Introduction of the semester system from the secondary stage in a phased manner, and the use of grades in place of marks.

## NECESSARY OF EXAMINATION REFORMS &CHALLENGES :

There are many reasons of reforming examination. According to National Focus Group, I have recommended eight (8) possible reasons why Examination Reforms is necessary.

1)There is need for functional and reliable system of school-based evaluation.

2)There is often a lack of full disclosure and transparency in grading.

3)While number of boards use good practices in pre-exam and exam management there remain several glaring shortfalls at several boards.

4)The quality of question papers is low. They usually call for rote memorization and fail to test higher-order skills like reasoning and analysis, let alone lateral thinking, creativity and judgment.

5)Indian School board exams are largely inappropriate for the 'knowledge society' of the 21st century and its need for innovative problem-solvers.

6)They do not serve the needs of social Justice.

7)They are inflexible. Based on a 'one-size-fits-all' principle, they make no allowance for different types of learners and learning environments.

8)They include a an inordinate level of anxiety and stress, In addition to widespread trauma, mass media and psychological counselors report a growing number of exam-induced suicides and nervous breakdowns.

## EXAMINATION REFORMS IN INDIA :

The Programme of Action (POA) suggested several specific short- term and long-term measures for carrying out examination reform at the school level as well as at the university level. It also suggested that, "to formulate a national examination reform work the Department of Education would, inter-alia, constitute an inter institutional Committee with representations from UGC, NCERT, AICTE and state level organisations including Board of Secondary Education. "

the POA (1986) has also envisaged the following strategies which are common for all stages (elementary, secondary, higher studies):

1. The emphasis will be laid on testing of expected levels of achievement of a variety of learning objectives in order to ensure due importance to higher abilities of understanding, application, analysis, synthesis, judgement and parallel parameters and not only to memory.

2. The Semester system introduced at the secondary stage and onwards should provide for flexibility in the combination of courses and accumulation of credits to enable the pupils to proceed at their own pace resulting in upward and horizontal mobility of the students across the country.

3. Appropriate courses in examination reform will be developed by Indira Gandhi National Open University through distance education mode in collaboration with NCERT for large scale training of different kinds and levels of personal.

4. An Examination Reform Centre will be established at the UGC for coordination, documentation and dissemination of information on examination reforms in higher education. Similarly, NCERT would perform this function at school stage.

5. Some laws will be introduced in the legislation regarding various malpractices connected with examinations. Such laws will make provision to prescribe the nature and type of punishment for various offences under the law.

6. A strong and coordinated effort should be made by the Centre and State Government regarding the monitoring and evaluation of the reforms in examinations and evaluation. Following up on NPE, 1986, NCERT conducted a National Seminar on Examination Reforms and issued certain guidelines to the States, principally covering the subjects of scaling and grading, continuous comprehensive internal evaluation, setting up of balanced question papers etc. Examination reforms have been recommended consistently by various Committees and Commissions over the years, steps for the same

have been taken differently in different states. Regarding examination reforms, the National Policy on Education Review Committee (NPERC) under the chairmanship of Acharya Ramamurty in 1990,

exhaustively reviewed the observations and recommendations made by different Committees and Commissions. During the course of the review, the NPERC also referred to the provision of NPE in regard to evaluation process and examination reforms. The NPERC also presented the status of the examination reforms in different states at the University and school levels.

The NPERC states that "Examination reform cannot be construed as an isolated activity to bring about process orientation. It has to go as a package along with reform in the structuring of courses and flexibility for students to avail of the restructured courses according to their convenience."

#### **CONCLUSION:**

It should be clear from the above discussion that examinations in India need serious reforming as well as it should also be recognized that examination reforms have the potential to lead educational reform. In order to reform the examination system, the educational institutions need to consistently strive towards excellence and chalk out new strategies. This can be done by organizing workshops, training sessions, refresher courses and all above all by developing an advanced work culture. Reforming examinations alone will attain very little unless it is accompanied by other basic reforms, improvement of teacher training, teacher quality and teacher-student ratio. In addition, make the curriculum and textbooks more relevant and interesting and challenging. At secondary level, spending more on education will be vital. It has often been lamented that in Indian education the tail (assessment) has usually wagged the dog (of learning and teaching). The de-emphasizing exams will certainly liberate the learning and teaching process from its straitjacket. But in the educational system this pivotal position of exams can be used to leverage age advantage - to hasten reform within Indian education as a whole.

# GUIDELINES FOR WRITING A RESEARCH PAPER FOR PUBLICATION

C.MADUMITHA(142016)/EEE /B

A primary task of a researcher is the communication of technical results to the broader scientific community. Whether in written or oral form, scientific communication is a critical step in the scientific method and is the key driver of movement within a scientific field. Therefore, the construction of a written scientific manuscript must not be taken lightly. As part of our service to the broader scientific community, we thought it may be beneficial to identify some of the common aspects of a well constructed scientific manuscript. These points are briefly discussed below. It should be noted that manuscripts that are successfully submitted to a journal for publication have three main components: (1) the overall idea, (2) the execution of the work, and (3) the presentation of the work. While each of these is critical, the guidelines presented below primarily speak to the third component, namely the presentation of the scientific work. Thus a poor idea or a poorly designed investigation cannot be saved by an excellent presentation of the work, and equally an excellent idea that is well investigated can still be doomed by a poor presentation. Hopefully the concepts described below will help to minimize the latter situation.

**Structure and Approach:** Scientific research must begin with a defined research question, which results in a well designed research protocol that plans the overall approach. This foundation should lead to a set of data from which the manuscript can be constructed. Manuscripts submitted to journals for consideration for publication typically have the following components.

- Title Page
- Abstract
- Introduction
- Methods
- Results

- Discussion
- Conclusions
- Acknowledgements
- References

A reasonable approach to writing a scientific manuscript may be the following. First write the Methods section, largely derived from your initial research protocol, and perhaps during the experimental phase of the work itself so that all details are included. Construct all of the figures and tables that contain the data included in the work, and then write the Results section. Depending upon the type of study, there may be some iteration in the presentation of the data and writing of the text. Reconsider the scientific questions the manuscript will address, again referring to your research protocol, and then write the Introduction. Next, use the Introduction and Results to guide the writing of the Discussion. Summarize everything in an Abstract, and then condense and refocus the Abstract into a Conclusions section. Below is a brief discussion of each of the sections. These are only suggestions on how a scientific manuscript may be written. Other strategies may also be used, but clarity should be the guiding principle. In general, the purpose of a scientific manuscript is to construct a clearly written document that describes a question and then logically presents an answer to this question that is based upon theoretical or experimental results. A scientific manuscript is meant to convey technical information to the reader. Therefore, it is generally designed to be a straightforward presentation and discussion. Paragraphs and sentences should be simply constructed.

**Title Page:** A title page should be included. State the title of the manuscript, which should be short and simple, as well as authors and author affiliations. Indicate the journal to which the manuscript is being



submitted. Provide approximately 5 key words, as well as a short title (sometimes referred to as a running title) for the manuscript. Finally, provide complete contact information for the corresponding author.

#### **ABSTRACT:**

The abstract is typically a single paragraph. The abstract should be considered as an independent document, so that the abstract does not rely upon any material in the body of the report and, similarly, the body of the report does not rely upon any material in the abstract. The first sentence should clearly state the objective of the experiment. If the experiment is based upon a hypothesis, which is greatly preferred, the hypothesis should be stated and followed with statements describing its basis and evaluation. The subsequent sentences describe how the investigation was carried out. The following sentences describe, with as much precision as possible without being verbose, the results of the experiment. The final sentences describe the significance of the results and the impact of this work on the general field of study.

#### **INTRODUCTION:**

The introduction requires a short review of the literature pertaining to the research topic. The introduction is then best constructed as a descriptive funnel, starting with broad topics and slowly focusing on the work at hand. Perhaps three to four paragraphs are needed. One approach may be to start with one or two paragraphs that introduce the reader to the general field of study. The subsequent paragraphs then describe how an aspect of this field could be improved. The final paragraph is critical. It clearly states, most likely in the first sentence of the paragraph, what experimental question will be answered by the present study. The hypothesis is then stated. Next, briefly describe the approach that was taken to test the hypothesis. Finally, a summary sentence may be added stating how the answer of your question will contribute to the overall field of study.

#### **METHODS:**

This section should be a straightforward description of the methods used in your study. Each method

should be described in a separate section. Begin, in a single section, with a statement of the materials used in the study, indicating the vendor and vendor contact information for each material. This information is critical so that readers have the capability to repeat the work in their own institutions. Next describe, in separate sections, each key procedure and technique used in the study. Keep explanations brief and concise. If a specific experimental design is utilized, describe this design in the second section of the Methods, after the materials section. Similarly, if a theoretical or modeling component is utilized, it should also be incorporated in the initial portion of the Methods. Finally, remember to describe the statistical analysis methods that were utilized to analyze the results, most likely in the final section of the Methods section.

#### **RESULTS:**

The Results section presents the experimental data to the reader, and is not a place for discussion or interpretation of the data. The data itself should be presented in tables and figures (see below). Introduce each group of tables and figures in a separate paragraph where the overall trends and data points of particular interest are noted. You may want to indicate the placement of a particular table or figure in the text. For experimental studies, key statistics such as the number of samples (n), the index of dispersion (SD, SEM), and the index of central tendency (mean, median or mode) must be stated. Include any statistical analysis that was performed, and make sure to indicate specific statistical data, such as p-values. Note that each table and figure in the paper must be referred to in the Results section. Be succinct.

#### **DISCUSSION:**

The discussion section, often the most difficult to write, should be relatively easy if the previous suggestions have been followed. In particular, look to the last paragraph of the introduction. If the work has characterized a phenomenon by studying specific effects, use the results to describe each effect in separate paragraphs. If the work has presented a hypothesis, use the results to construct a logical argument that supports or rejects your hypothesis. If

the work has identified three main objectives for the work, use the results to address each of these objectives. A well-defined study that is described in the Introduction, along with supporting results that are presented in the Results section, should ease the construction of the Discussion section. Begin the Discussion section with a brief paragraph that again gives an overview to the work. Summarize the most important findings and, if applicable, accept or reject the proposed hypothesis. Next, identify the most interesting, significant, remarkable findings that were presented in the Results section, and contrast these findings in light of other studies reported in the literature.

**Conclusions:** Again, first introduce the work and then briefly state the major results. Then state the major points of the discussion. Finally, end with a statement of how this work contributes to the overall field of study.

**Acknowledgements:** Provide a brief statement acknowledging the efforts of any participants or consultants who are not included as authors of the manuscript. State all of the funding sources for the work, ensuring that the statement adheres to the guidelines provided by the funding institution.



# VISION

TO BECOME A HIGH STANDARD OF EXCELLENCE IN EDUCATION,  
TRAINING AND RESEARCH IN THE FIELD OF  
ELECTRICAL AND ELECTRONICS ENGINEERING  
AND ALLIED APPLICATIONS



# MISSION

TO PRODUCE EXCELLENT, INNOVATIVE AND NATIONALISTIC ENGINEERS  
WITH ETHICAL VALUES AND TO ADVANCE IN  
THE FIELD OF ELECTRICAL AND ELECTRONICS ENGINEERING  
AND ALLIED AREAS